

# ACCU ELECTRIC MOTORS INC

USA: (888) 932-9183

CANADA: (905) 829-2505

- ✓ Over 100 years cumulative experience
- ✓ 24 hour rush turnaround / technical support service
- ✓ Established in 1993



The leading independent repairer of servo motors and drives in North America.

Visit us on the web:

[www.servo-repair.com](http://www.servo-repair.com)

[www.servorepair.ca](http://www.servorepair.ca)

[www.ferrocontrol.com](http://www.ferrocontrol.com)

[www.sandvikrepair.com](http://www.sandvikrepair.com)

[www.accuelectric.com](http://www.accuelectric.com)

**Scroll down to view your document!**

For 24/7 repair services :

USA: 1 (888) 932 - 9183

Canada: 1 (905) 829 -2505

Emergency After hours: 1 (416) 624 0386

Servicing USA and Canada

# BETRIEBSANLEITUNG

## INSTRUCTION MANUAL

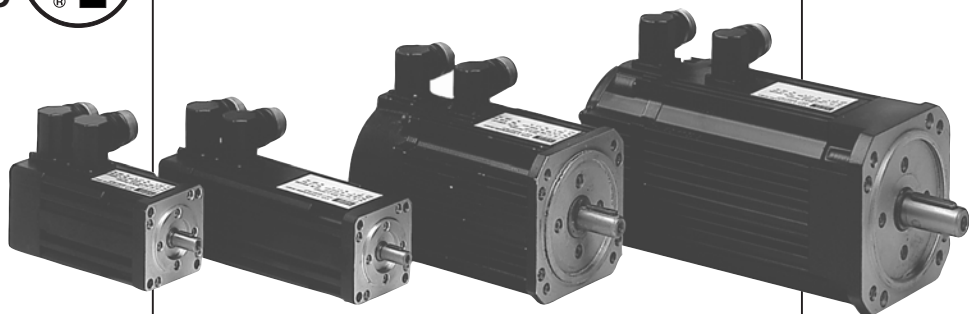

**KEB Servomotore**  
KEB Servo Motors

**Größe A1 . . . F3**  
Size A1 ... F3

Diese Betriebsanleitung beschreibt die Servomotoren A1...F3 und muß jedem Anwender zugänglich gemacht werden. Vor jeglichen Arbeiten muß sich der Anwender mit dem Gerät vertraut machen. Den **Sicherheits- und Warnhinweisen** in dieser Anleitung und in der Beschreibung für den Servosteller sowie in weiterer Dokumentation ist für einen sicheren Betrieb unbedingt Folge zu leisten. Die in dieser Anleitung aufgeführten Sicherheits- und Warnhinweise erheben keinen Anspruch auf Vollständigkeit. Die KEB Antriebstechnik GmbH behält sich das Recht vor, Spezifikationen und technische Daten ohne vorherige Benachrichtigung zu ändern, bzw. anzupassen.

Die in dieser Betriebsanleitung verwendeten Pictogramme entsprechen folgender Bedeutung:



### Gefahr / Warnung / Vorsicht

Wird verwendet, wenn Leben oder Gesundheit des Benutzers gefährdet sind oder erheblicher Sachschaden auftreten kann.



### Danger / Warning / Caution

Used when life or health of the user are exposed to danger or when the possibility of severe damage to the material exists.



### Achtung

Unbedingt beachten! Besondere Hinweise für den sicheren und störungsfreien Betrieb.



### Attention

Observe at all costs! Special instructions for a safe and trouble-free operation.



### Information

Hilfestellung, Tip



### Information

Assistance, Tips



**Nur qualifiziertes  
Elektro-  
Fachpersonal**

Alle Arbeiten zum Transport, Anschluß, zur Inbetriebnahme und Instandhaltung sind von qualifizierten, verantwortlichen Fach-

personal auszuführen. Unsachgemäßes Verhalten kann schwere Personen- und Sachschäden verursachen. Ein sicherer und störungsfreier Betrieb ist nur bei Einhaltung der jeweils gültigen Vorschriften gemäß DIN VDE 0100, IEC 1000, EN 60204-1, EN 55014, EN 50082-2 sowie einschlägiger örtlicher Bestimmungen gegeben.



**Only qualified  
Electro-  
personnel**

The KEB COMBIVERT is operated with voltages that can cause a severe electric shock dangerous to life.

Therefore the installation of the unit as well as of the available accessories is only permissible by qualified electro-personnel. A safe and trouble-free operation is only possible when the valid regulations according to DIN VDE 0100, IEC 1000, EN 60204-1, EN 55014, EN 50082-2 as well as the relevant regulations for your area are observed.

<b>1.</b>	<b>Introduction .....</b>	<b>4</b>
1.1	Intended Use .....	4
<b>2.</b>	<b>Safety Instructions .....</b>	<b>4</b>
<b>3.</b>	<b>Transport and Storage .....</b>	<b>5</b>
<b>4.</b>	<b>Installation .....</b>	<b>5</b>
4.1	Type of Protection .....	5
4.2	Ambient Temperature / Cooling .....	6
4.3	Output Components .....	6
<b>5.</b>	<b>Electrical Connection .....</b>	<b>6</b>
<b>6.</b>	<b>Operation and Maintenance .....</b>	<b>6</b>
<b>7.</b>	<b>Part Code .....</b>	<b>7</b>
<b>8.</b>	<b>Project Design .....</b>	<b>8</b>
8.1	Selection of the Servo Motor .....	8
8.2	Selection of the Servo Controller .....	8
<b>9.</b>	<b>Start-up .....</b>	<b>9</b>
9.1	Before Switching on .....	9
9.2	Switch on the Motor .....	9
<b>10.</b>	<b>Technical Data .....</b>	<b>10</b>
<b>11.</b>	<b>Torque-Speed Characteristic .....</b>	<b>19</b>
11.1	Motors of the 230 V-Class .....	19
11.2	Motors of the 400 V-Class .....	20
<b>12.</b>	<b>Axial and Lateral Force .....</b>	<b>21</b>
12.1	Shaft Load .....	22
12.2	Output Component .....	22
12.3	Pretension Factor .....	22
12.4	Horizontal Position of Use .....	23
12.5	Vertical Position of Use .....	23
<b>13.</b>	<b>Connection .....</b>	<b>24</b>
13.1	Connector Assignments .....	24
<b>14.</b>	<b>Options .....</b>	<b>26</b>
14.1	Holding Brake .....	26

## 1. Introduction

### 1.1 Intended Use

The synchronous servo motors KEB COMBIVERT SM serve for the operation on digital servo controllers and are intended for industrial systems. They comply to the harmonized standards of the series VDE 0530/EN 60034. The use in hazardous areas is prohibited, unless it is explicitly permitted (observe additional instructions).

## 2. Safety Instructions



- All works on the installation are to be carried out in a **de-energized** state.
- In the case of synchronous motors with rotating rotor a high voltage is applied onto the motor connections.
- After mounting the motor check the faultless function of the brake (if available).
- Repairs may be carried out only by the manufacturer or repair places authorized by him. Unauthorized opening and improper tampering can lead to bodily injuries or damages to property.
- Before starting up motors with featherkey in the shaft end, the featherkey must be secured against flinging out, if this is not already prevented through output components like belt pulley, clutches or similar elements.
- The motors are not intended for direct connection to the three-phase system. They must be operated by a servo controller. A direct power connection can lead to the destruction of the motor.
- The motors can reach a surface temperature of more than 100°C. No temperature-sensitive parts may lay close to or be attached onto the motor. If necessary, protective measurements must be taken against touching.
- The optional built-in deadlock holding brake is only designed for a limited number of emergency stops. The use as a working brake is not permitted.
- For motors with plug connection and built-in brake you must install the varistor required for the brake wiring at commissioning.
- The thermistor fitted in the winding is to be connected and evaluated by a suitable wiring, for the protection of the motor against thermal overload in case of slow changes. **Attention:** The thermistor does not represent an all-around protection of the winding.

### 3. Transport and Storage

After final tests all motors leave the factory in perfect condition. On delivery check the motor for outside damages. If you should determine transport damages, then a notice of damage is to be issued in the presence of the carrier. If necessary, **stop the commissioning** of these motors.

Screwed-in ring bolts are designed for the weight of the motors, i.e. the attachment of additional loads is prohibited.

The storage is only permitted in **closed, dry, dust-free, ventilated and non-vibrating** environments. Before commissioning measure the insulation resistance. In case of values  $\leq 1 \text{ k}\Omega$  per volt of rated voltage dry the winding (voltage of insulation resistance meter: 1000 V). After a longer storage (> 3 months) operate the motor at slow speed ( $\leq 100 \text{ min}^{-1}$ ) in both directions, so that the lubrication can spread evenly in the bearings.

Damages that occur as a result of improper handling are not subject to our warranty.

### 4. Installation

When installing the motor make sure of even supporting surface, solid foot or flange mounting and exact alignment in case of direct coupling. Turn the motor shaft by **hand** and listen for abnormal slipping noises.

#### 4.1 Type of Protection

The motors of the series A1...F3 are designed in the type of protection IP65 (shaft gland IP64, optionally with shaft sealing ring IP65). The only exception is the built-on version "Shaft end upwards" (IM V3, IM V36), as here no liquid may remain in the D-side flange bearing end-shield.

In the case of terminal box designs observe the correct sealing of the outgoing cables.

By turning the flange sockets or the terminal box any outgoing cable direction can be adjusted (rotatable by  $90^\circ$  each). **Attention:** In the case of improper execution of the work the type of protection IP65 is no longer warranted.

If connector systems are used, then the type of protection IP65 is only achieved with correctly wired and firmly tightened mating connector.

### 4.2 Ambient Temperature / Cooling

Ambient temperature:  $-5^{\circ}\text{C}$  . . .  $40^{\circ}\text{C}$  ( $194^{\circ}\text{F}$ )

Site altitude:  $\leq 1000$  m above sea level

The motor must be mounted in such a manner that the ventilation is not obstructed, i.e. sufficient heat dissipation through convection and radiation must be ensured.

If the motor is equipped with a separate ventilator, it must be connected correctly. The exhaust air of neighbouring units may not be sucked in again directly. For three-phase separate ventilator connection the correct direction of rotation is to be checked (direction arrow towards ventilator housing).

### 4.3 Output Components

The rotor of the motor is dynamically balanced through a full featherkey in the shaft end according to DIN 6885 Sheet 1.

For motors with built-in radial sealing ring (option) only a reduced maximum speed is permissible according to the instruction manual.

For putting on or taking off output components (gear wheels, belt pulleys, clutches and similar parts) suitable devices are to be used. The bracing must be carried out on the D-side shaft end (Drive-End).

**Attention:** Servo motors are precision drive components, no shocks or impacts may arrive at the motor.

### 5. Electrical Connection

All work may be carried out only by qualified technical personnel on the motor at rest in de-energized status and secured against restarting. Verify the safe isolation from supply!

The connection must be carried out in such a way that a permanently safe, electrical connection is maintained. Pay attention to a safe protective conductor connection.

### 6. Operation and Maintenance

In case of changes as compared to the normal operation, e.g. increased temperature, noises, oscillations, find out the cause, if necessary, contact the manufacturer. In case of doubt switch off the motor!

The maintenance of the motor is limited to the cleaning of the motor surface.

The radial groove ball bearings of the motor are lubricated for life and are designed for nominal service life of 20.000 hours.

Motors with shaft sealing ring must be built in in connection with transmissions, that prevent a dry running of the shaft sealing ring. Otherwise it comes to squeaking noises, and an overheating of the motor because of the increased friction.

## 7. Part Code

The KEB servo motors of series A1...F3 have the following standard design:

- UL/CSA - Acceptance test (E 234 973)
- Rotatable angular flange socket for encoder and motor connection
- Flange quality "R" according to DIN 42955
- Vibration quality "R" according to DIN ISO 2373
- Shaft end with featherkey balanced according to ISO 8821
- Resolver 2 pole
- Type of protection IP65 (IP64 at shaft gland)
- Type of construction B5
- PTC-resistor

Further definitions can be taken from the following key.

<b>A 1 . S M . 0 0 0 - 6 2 0 0</b>	
<b>Encoder</b>	0: 2-pole resolver A: Stegmann Hiperface Singleturn SRS 50/60 B: Stegmann Hiperface Multiturn SRM 50/60 C: Heidenhain EnDat Singleturn ECN 1113/1313 512 Inc D: Heidenhain EnDat Multiturn EQN 1125/1325 512 Inc F: Heidenhain Sin/Cos Encoder ERN 1387 2048 Inc H: Heidenhain Sin/Cos Encoder ERN 1185 512 Inc I: Heidenhain EnDat Singleturn ECI 1317 32 Inc J: Heidenhain EnDat Multiturn EQI 1329 32 Inc
<b>Connection</b>	0: Connector/connector turnable angular flange connector 1: Terminal box 9: Connector Size1,5
<b>Voltage</b>	2: 190 V (200V class)      4: 330 V (400V class)
<b>Speed</b>	1: 1500 RPM      4: 4000 RPM 2: 2000 RPM      6: 6000 RPM 3: 3000 RPM
<b>Version</b>	0: without brake; with feather key; IP65 (standard) 1: Standard with brake 2: Standard without feather key 3: Standard with brake, without feather key 4: Standard with oil-tight flange IP65 (Radial shaft seal ring) 5: Standard with brake and oil-tight flange 8: Standard with center hole M5 9: Standard with brake and center hole B: Standard without feather key and oil-tight flange C: Standard with brake, without feather key and oil-tight flange
<b>Cooling</b>	0: Self-cooling with flange B5 IFT5 compatible 1: Separate cooling with flange B5 IFT5 compatible 2: Self-cooling;foot 3: Separate cooling; foot
<b>Motor Type</b>	0: Three-phase synchronous motor
<b>Unit Type</b>	SM: Servo motor
<b>Size</b>	A1...F3

## 8. Project design

### 8.1 Selection of the Servo Motor

Calculate the following values before you selection the servo motor:

- Determine inertia ( $J_{App}$ ) of the application without motor
- Calculate required peak torque ( $M_{Lmax}$ ) of the application at the drive. The inertia of the motor ( $J_{Mot}$ ) can be accepted here with 1/5 inertia ( $J_{App}$ ) of the application.
- Determine the effective torque ( $M_{eff}$ ) via the time.

Now the motor can be selected on the basis of the calculated values and the technical data of the following pages. The following selection features must be observed:

calculate	motor data
$n_{max}$	$\leq n_N$
$M_{Lmax}$	$\leq M_{max}$
$M_{eff}$	$\leq M_{dN}$
$J_{App}/10$	$\leq J_{mot}$

For examination or optimization it can be calculated again with the real motor data.

### 8.2 Selection of the Servo Controller

The selection of the servo controller occurs via the max. short time current limit and the output rated current.

$$\text{Max. short time current limit} = \frac{M_{Lmax} \cdot \text{Stall current (Id0)}}{\text{Stall torque (Md0)}}$$

$$\text{Output rated current} = \frac{\text{Effective torque} \cdot \text{Stall current (Id0)}}{\text{Stall torque (Md0)}}$$

## **9. Start-up**

### **9.1 Before Switching on**

Before initial operation and after major inspections, check the complete plant both from a mechanical and electrical point of view.

The procedure should include checks that:

- the installation and the operating conditions comply with the specified name-plate data,
- the motor is properly installed and aligned,
- the driving elements are properly adjusted (e.g. proper belt tension, coupling properly aligned and balanced),
- the motor is properly wired (power cables and leads of monitoring devices),
- The earthing and equipotential bonding have been made as specified in the applicable regulations,
- all fastening screws, connecting elements and electrical connections are properly tightened,
- the key is safed unless prevented otherwise by driving elements such as pulleys, couplings etc.
- the forced ventilation is correctly connected and in proper service condition,
- the direction of rotation of the fan motor corresponds with the direction arrow on the fan housing,
- the cooling air flow is not impaired (the hot outlet cooling air must not be drawn in by the fan!),
- the brakes, if provided, are inspected for proper functioning.

### **9.2 Switch on the Motor**

The following measures are recommended to be taken after installing or inspecting the motors:

- Start the motor with no load.
- Check the mechanical running for any noise or vibrations on the bearings or end shields.
- If there is any abnormal noise or the motor runs unevenly, switch it off immediately and find out the cause.
- If the mechanical running improves immediately after the motor has been switched off, there is an electrical or magnetic cause. If this is not the case, there is a mechanical cause.
- If the mechanical running is smooth at no load, load the motor. Check the running smoothness, measure the voltage, current and power and record them. Measure and record these values also for the driven equipment, if possible.
- Monitor the temperatures of the bearings, windings etc. until they have stabilised and record the values (as far as this is possible with the available measuring equipment).

## 10. Technical Data

Servo motor		Ax.SM.000-yyyy							
Size (x) Voltage and speed variant (y)		A1		A2		A3		A4	
		6200	6400	6200	6400	6200	6400	6200	6400
Stall torque $M_{d0}$	Nm	0,34		0,50		0,65		1,0	
Current at stall torque $I_{d0}$	A	1,2	0,85	1,50	1	2	1,2	3,2	1,6
<b>Nominal Rating</b>									
Rated voltage $U_N$	V	230	400	230	400	230	400	230	400
Rated torque $M_N$	Nm	0,32		0,48		0,6		0,8	
Rated current $I_N$	A	1,0	0,8	1,5	0,9	2,0	1,1	2,9	1,4
Rated speed $n_N$	min <sup>-1</sup>	6000		6000		6000		6000	
Rated power $P_N$	W	200		300		375		500	
Voltage constant $k_E$ <sup>1)</sup>	V/1000min <sup>-1</sup>	28,3	39,0	28,3	46,4	28,3	49,8	28,3	56,6
Winding resistance $R_{u-v}$	Ohm	21	40,5	8,7	25,8	6,1	18,9	3,3	13,1
Winding inductance $L_{u-v}$	mH	9,9	18,7	5,4	14,5	3,9	12,2	2,7	10,7
<b>Max. values</b>									
max. torque $M_{max}$	Nm	1,7		2,5		3,2		5,0	
max. current $I_{max}$	A	7,1	5,0	9,0	6,0	10,8	6,5	17,0	8,5
<b>mechanical data</b> <sup>2)</sup>									
Inertia $J_L$	kgcm <sup>2</sup>	0,17		0,24		0,31		0,45	
Weight m	kg	1,0		1,2		1,4		1,8	

<sup>1)</sup> Specify the peak value of motor EMK at 1000 rpm as line-to-line voltage.

<sup>2)</sup> With resolver; without holding brake

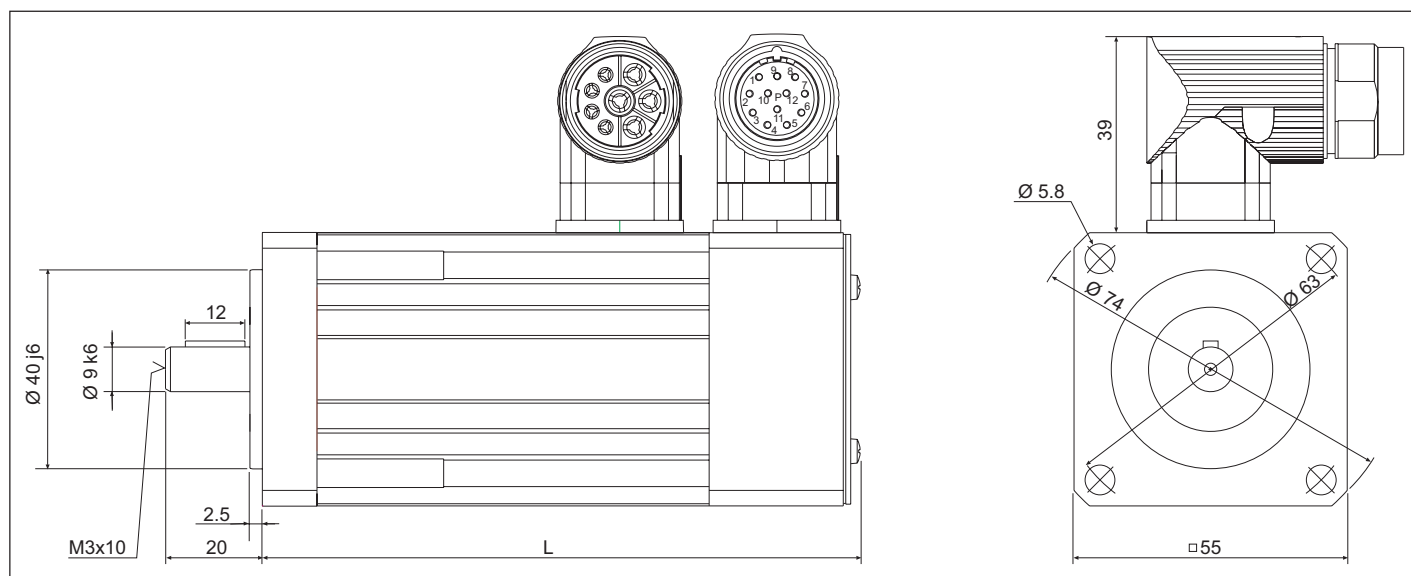

Length L						
Type	without brake			with brake		
Encoder	Resolver	SIN/COS	EnDat	Resolver	SIN/COS	EnDat
Size	-	ERN 1185	ECN1113/EQN1125	-	ERN 1185	ECN1113/EQN1125
A1	121	156	159	145	180	183
A2	133	168	168	157	192	195
A3	145	180	183	169	204	207
A4	170	205	208	194	229	232

Servo motor		Bx.SM.000-yyyy											
Size (x)		B1				B2				B3			
Voltage and speed variant (y)		4200	4400	6200	6400	4200	4400	6200	6400	4200	4400	6200	6400
Stall torque $M_{d0}$	Nm	0,65				1,5				2,3			
Current at stall torque $I_{d0}$	A	1,9	0,9	2,6	1,3	3,2	1,6	5,0	2,4	5,5	2,4	7,7	3,5
<b>Nominal Rating</b>													
Rated voltage $U_N$	V	230	400	230	400	230	400	230	400	230	400	230	400
Rated torque $M_N$	Nm	0,6		0,5		1,3		1,0		2,0		1,5	
Rated current $I_N$	A	2,0	0,9	2,5	1,2	2,9	1,4	4,4	2,1	4,7	2,0	6,6	3,0
Rated speed $n_N$	min <sup>-1</sup>	4000		6000		4000		6000		4000		6000	
Rated power $P_N$	W	250		310		540		620		830		940	
Voltage constant $k_E$ <sup>1)</sup>	V/1000min <sup>-1</sup>	29,4	67,7	21,8	45,4	39,2	80,9	25,2	53,0	37,2	85,4	26,3	59,1
Winding resistance $R_{U-V}$	Ohm	6,8	39,5	3,8	17	4	17,3	1,6	7	1,7	9,2	0,83	4,2
Winding inductance $L_{U-V}$	mH	11,5	61,1	6,3	27,4	11,5	48,8	4,8	21,0	5,6	29,4	2,8	14,1
<b>Max. values</b>													
max. torque $M_{max}$	Nm	3,1				7,2				11,0			
max. current $I_{max}$	A	11,4	5,4	15,6	7,8	19,2	9,6	30,0	14,4	33,0	14,4	46,2	21,0
<b>mechanical data</b> <sup>2)</sup>													
Inertia $J_L$	kgcm <sup>2</sup>	0,22				0,36				0,57			
Weight m	kg	1,5				2,1				2,9			

<sup>1)</sup> Specify the peak value of motor EMK at 1000 rpm as line-to-line voltage.

<sup>2)</sup> With resolver; without holding brake

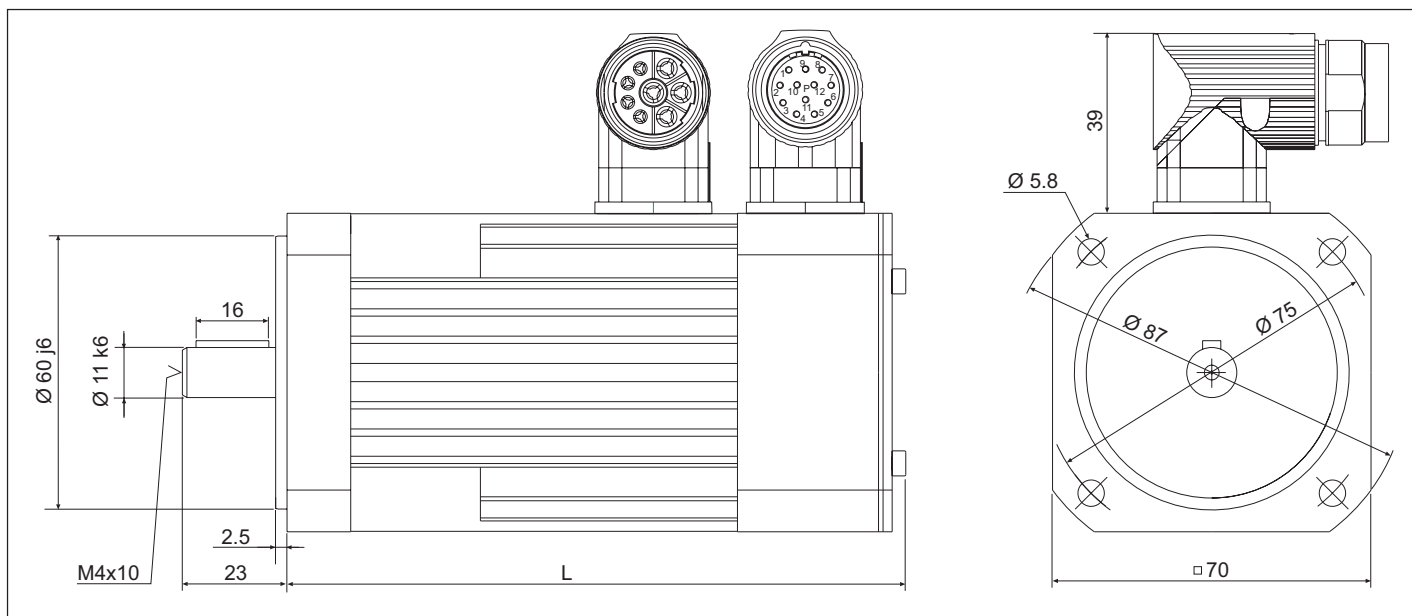

Length L											
Type	without brake					with brake					
Encoder	Resolver	SIN/COS	EnDat		Hiperface	Resolver	SIN/COS	EnDat		Hiperface	
Size	-	ERN 1185	ECN1113/EQN1125	EQI / ECI	SRS/M 50	-	ERN 1185	ECN1113/EQN1125	EQI/ECI	SRS/M 50	
B1	136	167	170	162	177	162	164	167	190	205	
B2	160	191	194	186	201	186	188	191	214	229	
B3	196	227	230	222	237	222	224	227	250	265	

# Technical Data

Servo motor		Cx.SM.000-yyyy									
Size (x)		C1					C2				
Voltage and speed variant (y)		3200	3400	4200	4400	6200	6400	3200	3400	4200	4400
Stall torque $M_{d0}$	Nm	0,95					2,7				
Current at stall torque $I_{d0}$	A	1,5	0,8	2,0	1,1	3,0	1,6	3,2	1,9	4,3	2,5
<b>Nominal Rating</b>											
Rated voltage $U_N$	V	230	400	230	400	230	400	230	400	230	400
Rated torque $M_N$	Nm	0,8		0,75		0,7		2,4		2,2	
Rated current $I_{dN}$	A	1,4	0,75	1,8	0,9	2,4	1,3	3,0	1,8	3,6	2,1
Rated speed $n_N$	min <sup>-1</sup>	3000		4000		6000		3000		4000	
Rated power $P_N$	W	0,25		0,31		0,44		0,75		0,92	
Voltage constant $k_E$ <sup>1)</sup>	V/1000min <sup>-1</sup>	51,6	94,0	38,9	71,0	25,9	47,5	64,3	111,0	48,5	83,4
Winding resistance $R_{U-V}$	Ohm	20,5	74,9	12,1	39,4	5,1	18,9	4,2	13,1	2,3	6,9
Winding inductance $L_{U-V}$	mH	30,5	101	17,1	57,6	7,6	25,9	11,4	34,4	6,5	19,3
<b>Max. values</b>											
max. torque $M_{max}$	Nm	4,3					12,2				
max. current $I_{max}$	A	7,5	4,0	10,0	5,4	15,0	8,0	16,0	9,4	21,5	12,4
<b>mechanical data</b> <sup>2)</sup>											
Inertia $J_L$	kgcm <sup>2</sup>	1,2					2,7				
Weight m	kg	2,7					3,9				

<sup>1)</sup> Specify the peak value of motor EMK at 1000 rpm as line-to-line voltage.

<sup>2)</sup> With resolver; without holding brake

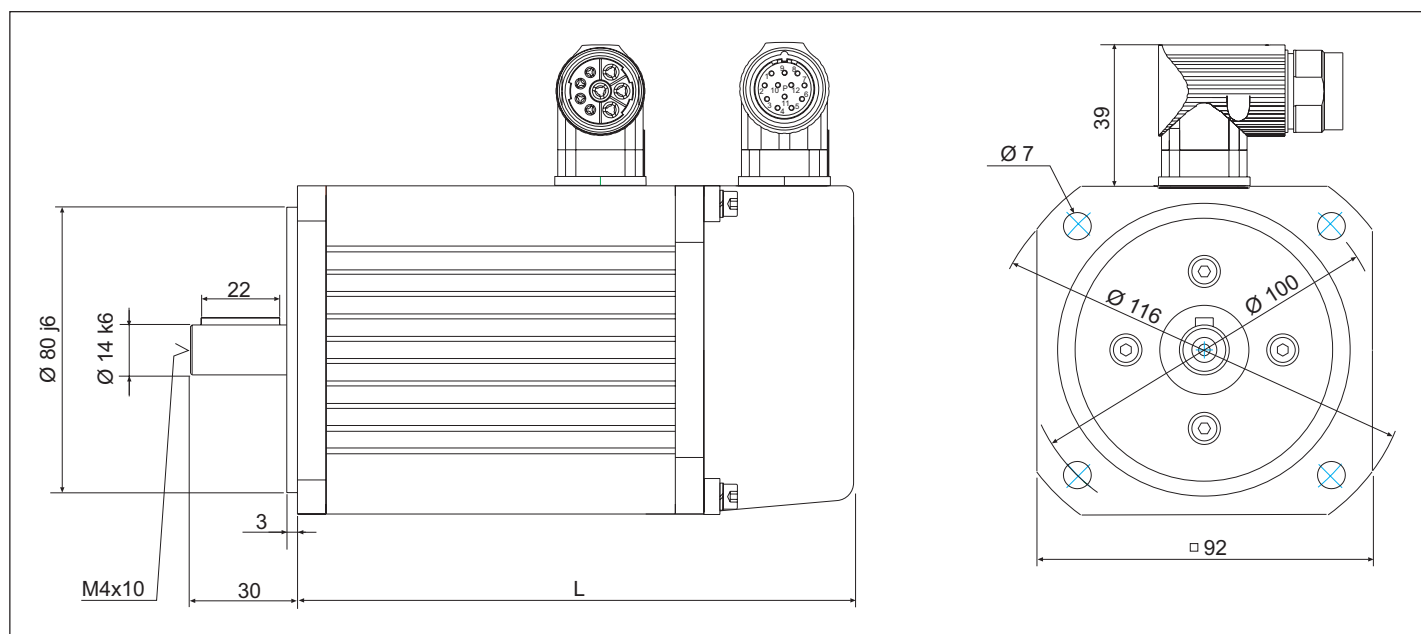

Length L											
Type	without brake					with brake					
Encoder	Resolver	SIN/COS	EnDat		Hiperface	Resolver	SIN/COS	EnDat		Hiperface	
Size	-	ERN 1387	ECN1313/EQN1325	EQI / ECI	SRS/M 50	-	ERN 1387	ECN1313/EQN1325	EQI/ECI	SRS/M 50	
C1	156	193	201	193	163	192	229	237	229	199	
C2	180	217	225	217	187	226	263	271	263	233	
C3	214	251	259	251	221	260	297	305	297	267	
C4	248	285	293	285	255	294	331	339	331	301	

Cx.SM.000-yyyy													
C2		C3						C4					
6200	6400	3200	3400	4200	4400	6200	6400	3200	3400	4200	4400	6200	6400
2,7		4,5						6					
6,5	3,7	5,1	2,9	6,7	3,8	9,9	5,6	7,1	4,2	9,1	5,5	13,7	7,8
230	400	230	400	230	400	230	400	230	400	230	400	230	400
2,0		3,9		3,5		2,8		5,0		4,5		3,0	
5,3	3,0	4,6	2,7	5,5	3,1	6,7	3,8	6,3	3,7	7,3	4,4	7,9	4,5
6000		3000		4000		6000		3000		4000		6000	
1,25		1,22		1,47		1,76		1,57		1,88		1,88	
33,0	55,7	69,4	118,0	52,6	90,8	35,4	61,4	67,7	113,0	53,0	86,7	34,9	60,1
0,95	3,3	2	5,9	1,1	3,7	0,54	1,7	1,2	3,4	0,74	2,1	0,32	1,03
2,7	8,6	6,9	20,6	4	12,2	1,8	5,7	4,5	13,1	2,8	7,8	1,2	3,8
12,2		20,3						27,0					
32,5	18,5	25,5	14,5	33,4	19,0	49,5	27,9	35,5	21,0	45,5	27,5	68,4	39,0
2,7		4,2						5,4					
3,9		5,2						6,6					

# Technical Data

Servo motor		Dx.SM.000-yyyy									
Size (x)		D1						D2			
Voltage and speed variant (y)		3200	3400	4200	4400	6200	6400	3200	3400	4200	4400
Stall torque $M_{d0}$	Nm	4,2						7			
Current at stall torque $I_{d0}$	A	5,3	3,0	7,0	4,0	10,2	6,0	8,5	4,8	11,6	6,4
<b>Nominal Rating</b>											
Rated voltage $U_N$	V	230	400	230	400	230	400	230	400	230	400
Rated torque $M_N$	Nm	3,7		3,50		3,0		6,1		5,8	
Rated current $I_N$	A	4,9	2,80	6,1	3,5	8,2	4,8	8,1	4,5	10,5	5,8
Rated speed $n_N$	min <sup>-1</sup>	3000		4000		6000		3000		4000	
Rated power $P_N$	W	1,2		1,5		1,9		1,9		2,4	
Voltage constant $k_E$ <sup>1)</sup>	V/1000min <sup>-1</sup>	66,5	117,0	50,5	87,7	34,5	58,4	66,9	119,8	48,9	89,0
Winding resistance $R_{U-V}$	Ohm	2,1	6,3	1,2	3,9	0,55	1,6	1	3,2	0,5	1,7
Winding inductance $L_{U-V}$	mH	7,7	23,8	4,5	13,4	2,1	6	4	12,8	2,2	7,05
<b>Max. values</b>											
max. torque $M_{max}$	Nm	18,9						31,5			
max. current $I_{max}$	A	25,4	14,4	33,6	19,2	48,9	28,8	40,8	23,0	55,7	30,7
<b>mechanical data</b> <sup>2)</sup>											
Inertia $J_L$	kgcm <sup>2</sup>	4,8						7,4			
Weight m	kg	6,3						7,9			

<sup>1)</sup> Specify the peak value of motor EMK at 1000 rpm as line-to-line voltage.

<sup>2)</sup> With resolver; without holding brake

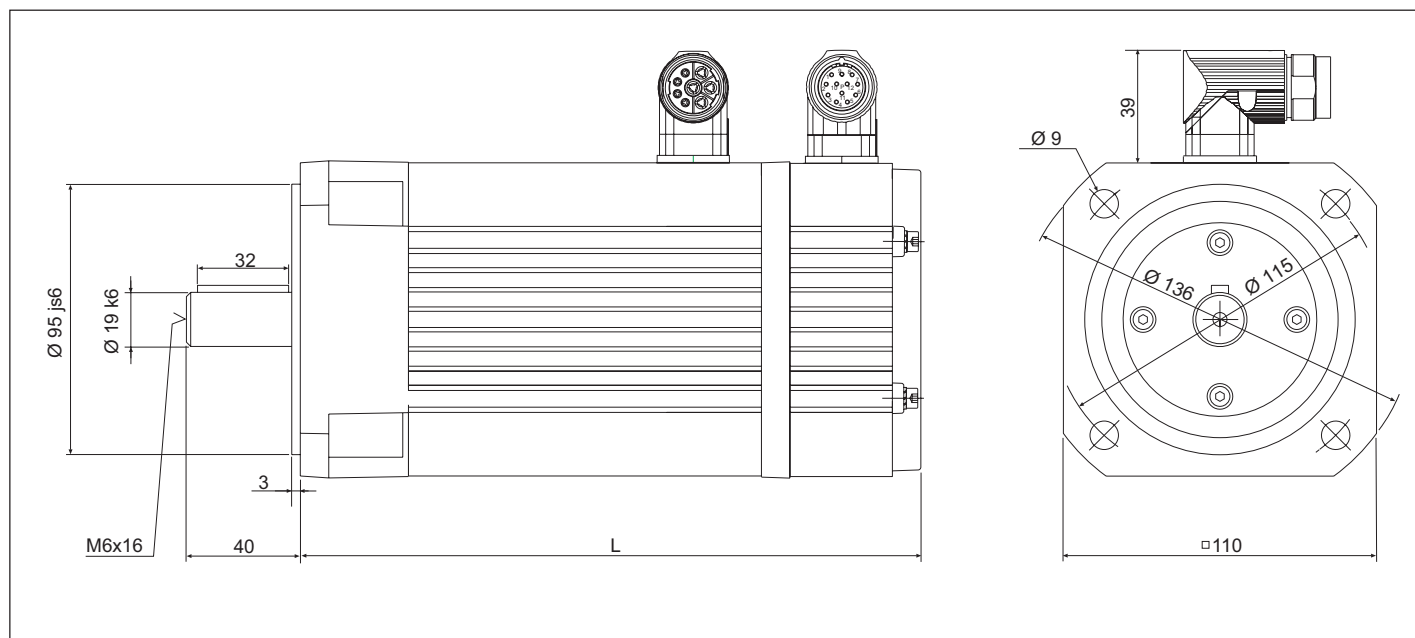

Length L											
Type	without brake					with brake					
Encoder	Resolver	SIN/COS	EnDat		Hiperface	Resolver	SIN/COS	EnDat		Hiperface	
Size	-	ERN 1387	ECN1313/EQN1325	EQI / ECI	SRS/M 50	-	ERN 1387	ECN1313/EQN1325	EQI/ECI	SRS/M 50	
D1	218	248	256	248	255	225	255	263	255	262	
D2	248	278	286	278	285	255	285	293	285	292	
D3	278	308	316	308	315	285	315	323	315	322	
D4	308	338	346	338	345	315	345	353	345	352	

Dx.SM.000-yyyy											
D2		D3						D4			
6200	6400	3200	3400	4200	4400	6200	6400	3200	3400	4200	4400
7		10						12			
16,0	9,9	12,4	7,2	17,0	9,7	22,6	13,6	14,2	8,5	18,2	11,6
230	400	230	400	230	400	230	400	230	400	230	400
3,8		8,4		7,6		5,0		9,9		8,6	
9,6	5,9	10,9	6,3	13,5	7,7	12,7	7,6	12,2	7,3	13,5	8,6
6000		3000		4000		6000		3000		4000	
2,4		2,6		3,2		3,1		3,1		3,6	
35,5	57,8	69,3	119,8	50,5	88,2	37,9	63,1	73,1	121,5	56,7	89,2
0,27	0,7	0,6	1,9	0,33	1,04	0,18	0,57	0,5	1,4	0,3	0,76
1,1	3,0	2,8	8,3	1,5	4,5	0,83	2,3	2,4	6,7	1,5	3,6
31,5		45,0						54,0			
76,8	47,5	59,5	34,5	81,6	46,5	108,0	65,3	68,1	40,8	87,3	55,7
7,4		9,8						12,7			
7,9		9,6						11,2			

# Technical Data

Servo motor		Ex.SM.000-yyyy									
Size (x)		E1					E2				
Voltage and speed variant (y)		2200	2400	3200	3400	4200	4400	2200	2400	3200	3400
Stall torque $M_{d0}$	Nm	8,5					14				
Current at stall torque $I_{d0}$	A	5,3	3,1	8,0	4,7	10,7	6,2	8,6	4,7	13,3	7,5
<b>Nominal Rating</b>											
Rated voltage $U_N$	V	230	400	230	400	230	400	230	400	230	400
Rated torque $M_N$	Nm	7,0		6,5		5,2		12,2		11,0	
Rated current $I_N$	A	4,4	2,6	6,4	3,8	6,9	4,0	7,5	4,1	10,4	5,8
Rated speed $n_N$	min <sup>-1</sup>	2000		3000		4000		2000		3000	
Rated power $P_N$	W	1,5		2		2,2		2,6		3,5	
Voltage constant $k_E$ <sup>1)</sup>	V/1000min <sup>-1</sup>	145,5	249,6	96,4	164,9	72,4	124,5	152,6	255,0	101,7	168,9
Winding resistance $R_{U-V}$	Ohm	3,5	10,2	1,5	4,4	0,85	2,6	1,37	4,3	0,6	2
Winding inductance $L_{U-V}$	mH	9,9	29,3	4,4	12,7	2,5	6,8	6,1	17,9	2,7	8,2
<b>Max. values</b>											
max. torque $M_{max}$	Nm	42,0					70,0				
max. current $I_{max}$	A	28	16	42	25	57	33	46	25	71	40
<b>mechanical data</b> <sup>2)</sup>											
Inertia $J_L$	kgcm <sup>2</sup>	12,3					19,5				
Weight m	kg	10,2					12,3				

<sup>1)</sup> Specify the peak value of motor EMK at 1000 rpm as line-to-line voltage.

<sup>2)</sup> With resolver; without holding brake

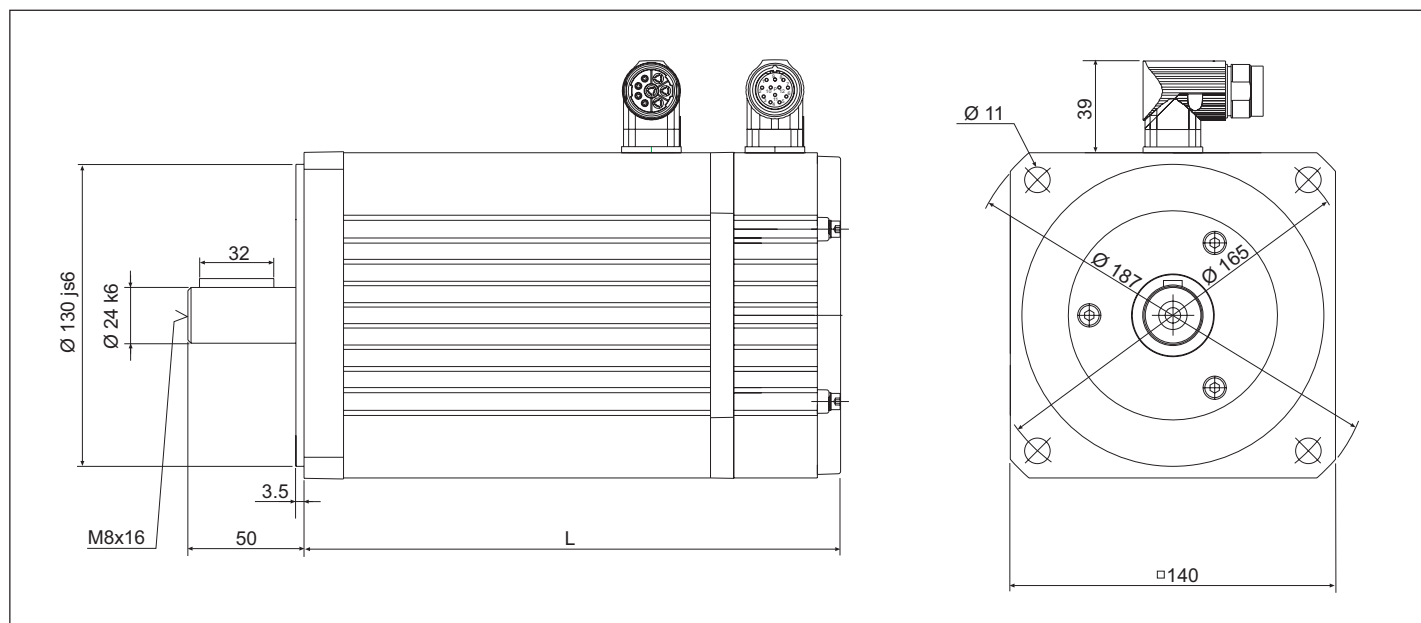

Length L											
Type	without brake					with brake					
Encoder	Resolver	SIN/COS	EnDat		Hiperface	Resolver	SIN/COS	EnDat		Hiperface	
Size	-	ERN 1387	ECN1313/EQN1325	EQI / ECI	SRS/M 50	-	ERN 1387	ECN1313/EQN1325	EQI/ECI	SRS/M 50	
E1	231	263	271	263	238	276	308	316	308	283	
E2	261	293	301	293	268	306	338	346	338	313	
E3	291	323	331	323	298	336	368	376	368	343	
E4	336	368	376	368	343	381	413	421	413	388	

Ex.SM.000-yyyy											
E2		E3						E4			
4200	4400	2200	2400	3200	3400	4200	4400	2200	2400	3200	3400
14		19						27			
17,8	10,0	11,7	6,8	17,6	10,3	21,9	13,5	16,5	9,9	23,2	14,4
230	400	230	400	230	400	230	400	230	400	230	400
7,6		16,5		14,6		8,7		21,4		15,5	
9,7	5,4	10,6	6,1	14,0	8,3	10,4	6,4	13,0	7,8	13,3	8,3
4000		2000		3000		4000		2000		3000	
3,2		3,5		4,6		3,6		4,5		4,9	
79,8	128,1	143,1	247,9	95,5	162,2	76,2	124,0	152,6	259,5	110,5	177,1
0,38	1,14	0,85	2,6	0,38	1,11	0,24	0,64	0,57	1,7	0,29	0,81
1,7	4,7	4,2	9,9	1,9	5,1	1,3	3,0	2,5	7,2	1,3	3,4
70,0		85,0						121,0			
94	53	56	33	84	49	105	65	79	47	111	69
19,5		26,7						36			
12,3		15,5						20,4			

# Technical Data

Servo motor		Fx.SM.000-yyyy									
Size (x)		F1				F2			F3		
Voltage and speed variant (y)		1400	2400	3400	4400	1400	2400	3400	1400	2400	3400
Stall torque $M_{d0}$	Nm	25				50			70		
Current at stall torque $I_{d0}$	A	8,2	11,1	17,0	22,2	17,0	22,3	32,2	23,1	30,8	46,2
<b>Nominal Rating</b>											
Rated voltage $U_N$	V	400				400			400		
Rated torque $M_N$	Nm	22,5	21,5	20,0	16,0	42,0	38,0	31,0	61,0	52,0	33,0
Rated current $I_N$	A	7,5	9,7	13,8	14,8	14,5	17,2	20,6	20,9	23,7	22,9
Rated speed $n_N$	min <sup>-1</sup>	1500	2000	3000	4000	1500	2000	3000	1500	2000	3000
Rated power $P_N$	W	3,5	4,5	6,3	6,7	6,6	7,9	9,7	9,6	10,9	10,4
Voltage constant $k_E$ <sup>1)</sup>	V/1000min <sup>-1</sup>	267,6	198,8	130,0	99,4	254,0	194,2	134,5	261,1	195,7	130,5
Winding resistance $R_{U-V}$	Ohm	2,36	1,36	0,58	0,34	0,81	0,48	0,23	0,51	0,3	0,13
Winding inductance $L_{U-V}$	mH	29,7	16,4	7	4,1	12,8	7,5	3,6	6,8	3,8	1,7
<b>Max. values</b>											
max. torque $M_{max}$	Nm	88,0				175,0			245,0		
max. current $I_{max}$	A	29	39	60	78	60	78	113	81	108	162
<b>mechanical data</b> <sup>2)</sup>											
Inertia $J_L$	kgcm <sup>2</sup>	84				147			210		
Weight m	kg	30,5				44,0			57,5		

<sup>1)</sup> Specify the peak value of motor EMK at 1000 rpm as line-to-line voltage.

<sup>2)</sup> With resolver; without holding brake

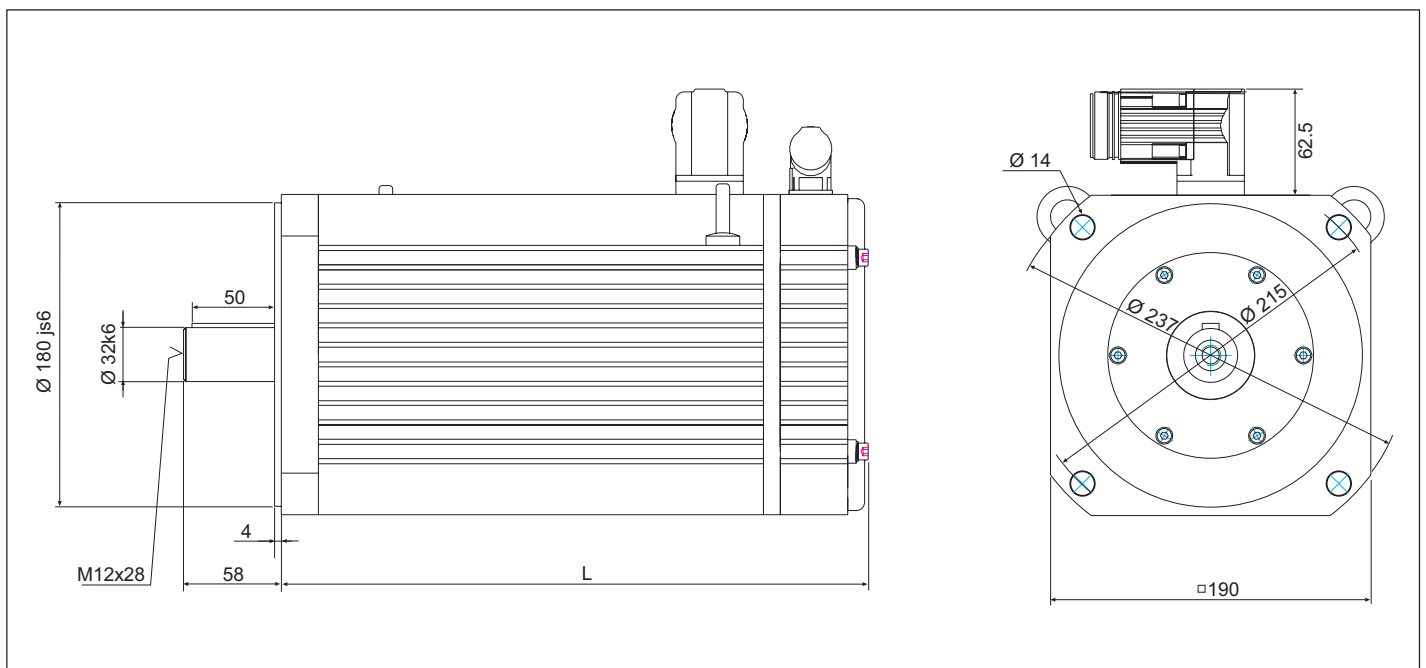

Length L											
Type	without brake					with brake					
Encoder	Resolver	SIN/COS	EnDat		Hiperface	Resolver	SIN/COS	EnDat		Hiperface	
Size	-	ERN 1387	ECN1313/EQN1325	EQI / ECI	SRS/M 50	-	ERN 1387	ECN1313/EQN1325	EQI/ECI	SRS/M 50	
F1	348	385	393	385	355	348	385	393	385	355	
F2	428	465	473	465	466	428	465	473	465	435	
F3	508	545	553	545	546	508	545	553	545	515	

## 11. Torque-Speed Characteristic

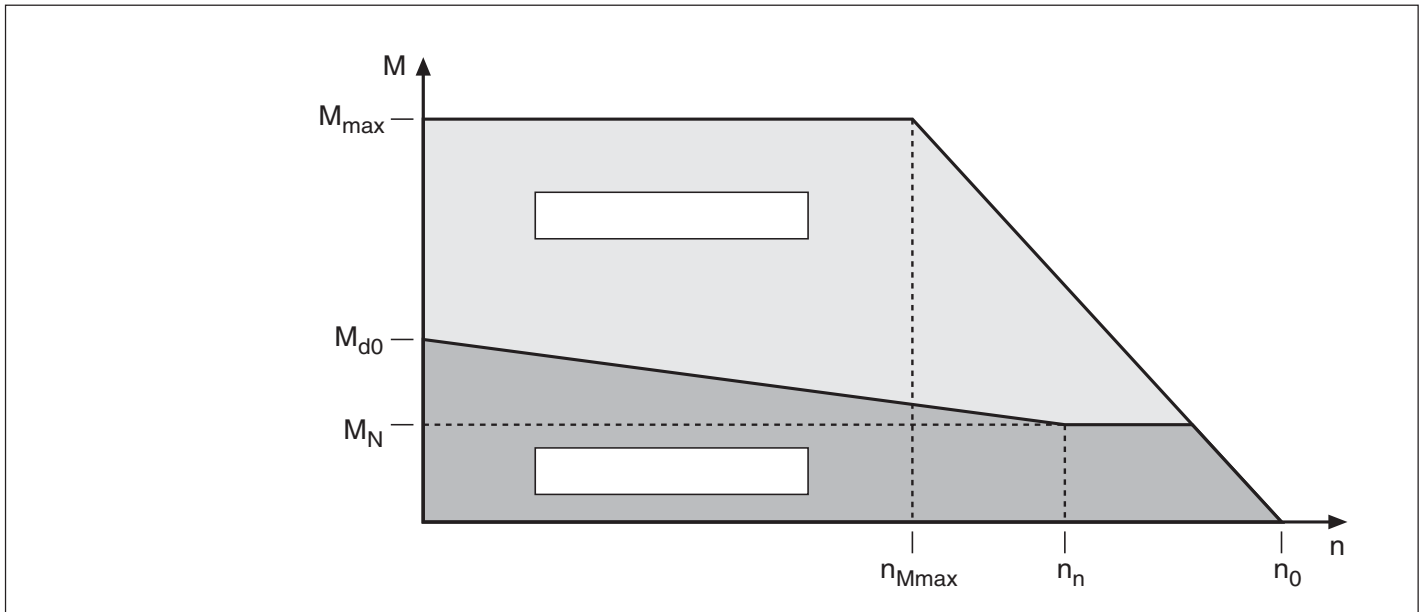

### 11.1 Motors of the 230 V Class

KEB Part.No.	$M_{\max}$	$M_N$ [Nm]	$M_{d0}$	$n_n$	$n_{M\max}$ [rpm]	$n_0$
A1.SM.000-6200	1,7	0,32	0,34	6000	5950	9500
A2.SM.000-6200	2,5	0,48	0,5	6000	6950	9500
A3.SM.000-6200	3,2	0,6	0,65	6000	7100	9500
A4.SM.000-6200	5	0,8	1	6000	7850	9500
B1.SM.000-4200	3,1	0,6	0,65	4000	5250	9100
B1.SM.000-6200	3,1	0,5	0,65	6000	7250	12300
B2.SM.000-4200	7,2	1,3	1,5	4000	3450	6850
B2.SM.000-6200	7,2	1	1,5	6000	6000	10650
B3.SM.000-4200	11	2	2,3	4000	4700	7200
B3.SM.000-6200	11	1,5	2,3	6000	5950	10200
C1.SM.000-3200	4,3	0,8	0,95	3000	1800	5200
C1.SM.000-4200	4,3	0,75	0,95	4000	2850	6900
C1.SM.000-6200	4,3	0,7	0,95	6000	5350	10350
C2.SM.000-3200	12,2	2,4	2,7	3000	2550	4150
C2.SM.000-4200	12,2	2,2	2,7	4000	3950	5500
C2.SM.000-6200	12,2	2	2,7	6000	6150	8150
C3.SM.000-3200	20,3	3,9	4,5	3000	2600	3850
C3.SM.000-4200	20,3	3,5	4,5	4000	3850	5100
C3.SM.000-6200	20,3	2,8	4,5	6000	5550	7600
C4.SM.000-3200	27	5	6	3000	2600	3950
C4.SM.000-4200	27	4,5	6	4000	3600	5050
C4.SM.000-6200	27	3	6	6000	6300	7650

KEB Part.No.	$M_{\max}$	$M_N$ [Nm]	$M_{d0}$	$n_n$	$n_{M\max}$ [rpm]	$n_0$
D1.SM.000-3200	18,9	3,7	4,2	3000	2550	4000
D1.SM.000-4200	18,9	3,5	4,2	4000	3850	5300
D1.SM.000-6200	18,9	3	4,2	6000	5350	7750
D2.SM.000-3200	31,5	6,1	7	3000	2750	4000
D2.SM.000-4200	31,5	5,8	7	4000	4000	5450
D2.SM.000-6200	31,5	3,8	7	6000	6300	7550
D3.SM.000-3200	45	8,4	10	3000	2850	3850
D3.SM.000-4200	45	7,6	10	4000	3950	5300
D3.SM.000-6200	45	5	10	6000	5600	7050
D4.SM.000-3200	54	9,9	12	3000	2850	3650
D4.SM.000-4200	54	8,6	12	4000	3550	4700
E1.SM.000-2200	42	7	8,5	2000	1500	2250
E1.SM.000-3200	42	6,5	8,5	3000	2250	3450
E1.SM.000-4200	42	5,2	8,5	4000	3400	4600
E2.SM.000-2200	70	12,2	14	2000	1450	2150
E2.SM.000-3200	70	11	14	3000	2150	3250
E2.SM.000-4200	70	7,6	14	4000	3300	4150
E3.SM.000-2200	85	16,5	19	2000	1450	2300
E3.SM.000-3200	85	14,6	19	3000	3450	3450
E3.SM.000-4200	85	8,7	19	4000	3400	4350
E4.SM.000-2200	121	21,4	27	2000	1700	2150
E4.SM.000-3200	121	15,5	27	3000	2500	3000

## Torque-Speed Characteristic

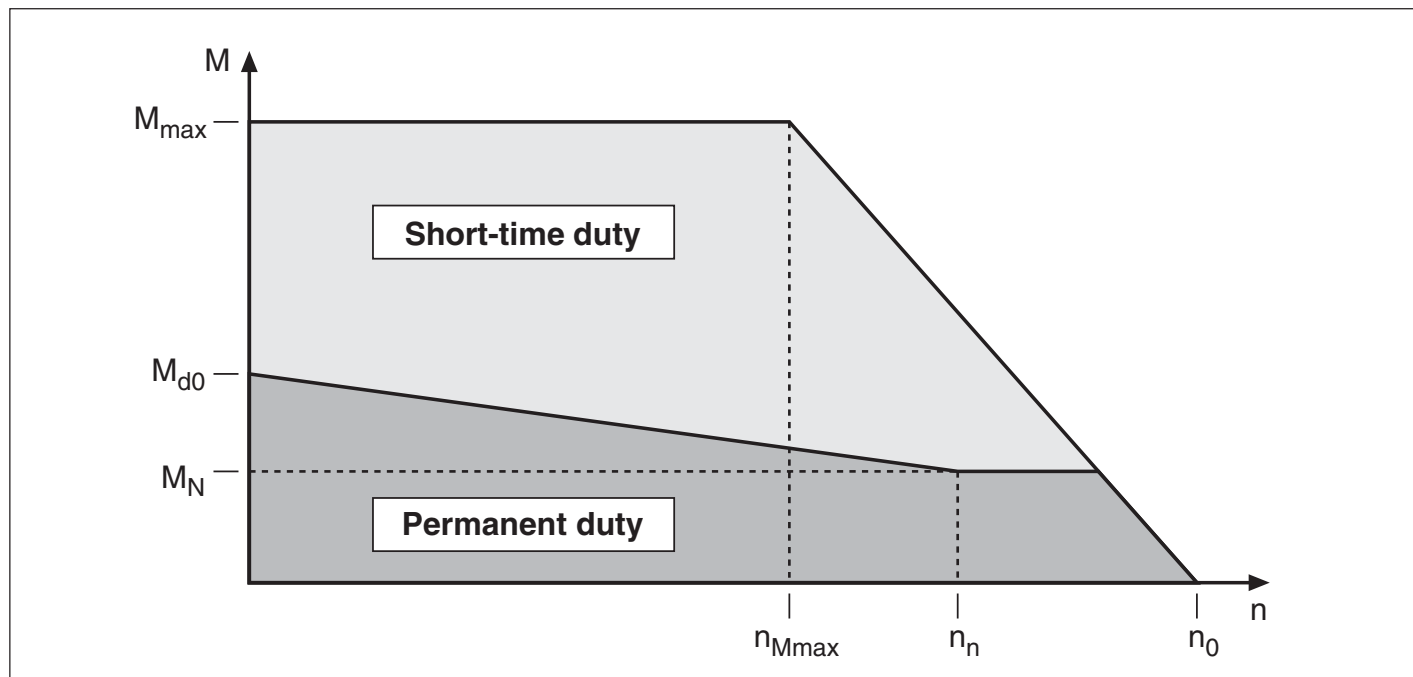

### 11.2 Motors of the 400 V Class

KEB Part.No.	$M_{max}$	$M_N$ [Nm]	$M_{d0}$	$n_n$	$n_{Mmax}$ [rpm]	$n_0$
A1.SM.000-6400	1,7	0,32	0,34	6000	7550	11950
A2.SM.000-6400	2,5	0,48	0,5	6000	6900	10050
A3.SM.000-6400	3,2	0,6	0,65	6000	6600	9350
A4.SM.000-6400	5	0,8	1	6000	6000	8250
B1.SM.000-4400	3,1	0,6	0,65	4000	2800	6850
B1.SM.000-6400	3,1	0,5	0,65	6000	5200	10250
B2.SM.000-4400	7,2	1,3	1,5	4000	1850	5750
B2.SM.000-6400	7,2	1	1,5	6000	4800	8800
B3.SM.000-4400	11	2	2,3	4000	3100	5450
B3.SM.000-6400	11	1,5	2,3	6000	4500	7850
C1.SM.000-3400	4,3	0,8	0,95	3000	1500	4950
C1.SM.000-4400	4,3	0,75	0,95	4000	2850	6550
C1.SM.000-6400	4,3	0,7	0,95	6000	4750	9800
C2.SM.000-3400	12,2	2,4	2,7	3000	2500	4150
C2.SM.000-4400	12,2	2,2	2,7	4000	4000	5550
C2.SM.000-6400	12,2	2	2,7	6000	6150	8350
C3.SM.000-3400	20,3	3,9	4,5	3000	2650	3950
C3.SM.000-4400	20,3	3,5	4,5	4000	3850	5100
C3.SM.000-6400	20,3	2,8	4,5	6000	5450	7600
C4.SM.000-3400	27	5	6	3000	2750	4100
C4.SM.000-4400	27	4,5	6	4000	3950	5350
C4.SM.000-6400	27	3	6	6000	6300	7750
D1.SM.000-3400	18,9	3,7	4,2	3000	2500	3950
D1.SM.000-4400	18,9	3,5	4,2	4000	3850	5300
D1.SM.000-6400	18,9	3	4,2	6000	5600	7950
D2.SM.000-3400	31,5	6,1	7	3000	2650	3900
D2.SM.000-4400	31,5	5,8	7	4000	3650	5200

KEB Part.No.	$M_{max}$	$M_N$ [Nm]	$M_{d0}$	$n_n$	$n_{Mmax}$ [rpm]	$n_0$
D2.SM.000-6400	31,5	3,8	7	6000	6550	8050
D3.SM.000-3400	45	8,4	10	3000	2850	3850
D3.SM.000-4400	45	7,6	10	4000	3900	5250
D3.SM.000-6400	45	5	10	6000	5900	7350
D4.SM.000-3400	54	9,9	12	3000	3000	3800
D4.SM.000-4400	54	8,6	12	4000	4150	5200
E1.SM.000-2400	42	7	8,5	2000	1550	2300
E1.SM.000-3400	42	6,5	8,5	3000	2350	3500
E1.SM.000-4400	42	5,2	8,5	4000	3550	4600
E2.SM.000-2400	70	12,2	14	2000	1550	2250
E2.SM.000-3400	70	11	14	3000	2500	3400
E2.SM.000-4400	70	7,6	14	4000	3600	4500
E3.SM.000-2400	85	16,5	19	2000	1800	2300
E3.SM.000-3400	85	14,6	19	3000	2750	3550
E3.SM.000-4400	85	8,7	19	4000	3850	4650
E4.SM.000-2400	121	21,4	27	2000	1700	2200
E4.SM.000-3400	121	15,5	27	3000	2650	3250
F1.SM.000-1400	88	22,5	25	1500	600	1700
F1.SM.000-2400	88	21,5	25	2000	1200	2300
F1.SM.000-3400	88	20	25	3000	1800	3550
F1.SM.000-4400	88	16	25	4000	2850	4650
F2.SM.000-1400	175	42	50	1500	950	1800
F2.SM.000-2400	175	38	50	2000	1300	2400
F2.SM.000-3400	175	31	50	3000	2300	3450
F3.SM.000-1400	245	61	70	1500	1200	1750
F3.SM.000-2400	245	52	70	2000	1700	2350
F3.SM.000-3400	245	33	70	3000	2900	3550

## 12. Axial and Lateral Force

The table specifies:

- the largest permissible lateral force  $F_{Rm}$  at  $x=l_1/2$
- the largest permissible axial force  $F_{Am}$  for a service life of 20000 hours.

Motor	Lateral force $F_{Rm}$ [N] at speed n [rpm]				Axial force $F_{Am}$ [N] at speed n [rpm]				$d_1$ $l_1$	$F_G$ [N]	P [mm]	C [mm]	$F_{Rmax}$ [N]
	2000	3000	4000	6000	2000	3000	4000	6000					
A1	310	260	240	210	250	200	170	140	9 k6 20	1	10	96	600
A2										2		108	
A3										3		121	
A4										4		145	
B1	400	340	300	270	310	260	220	180	11 j6 23	2	11	81	800
B2										4		105	
B3										6		141	
C1	470	400	350	320	380	310	260	220	14 k6 30	3	17	131	1000
C2										9		155	
C3										14		189	
C4										20		223	
D1	720	640	550	490	590	500	420	350	19 k6 40	10	24	138	2000
D2										17		168	
D3										23		198	
D4										30		228	
E1	1100	1000	850	-	900	770	650	560	24 k6 50	17	24	188	2300
E2										30		218	
E3										40		248	
E4										60		293	
F1	2300	1900	1800	-	1800	1500	1400	-	32 k6 58	85	31	280	6000
F2										140		360	
F3										200		440	

Legend	$F_{Rm}$ :	Permissible lateral force
	$F_{Rmax}$ :	max. permissible dynamic lateral force
	$F_{Am}$ :	Permissible Axial force
	$d_1$ :	Shaft end diameter
	$l_1$ :	Length of the shaft end
	$F_G$ :	Mass force of the rotor
	P:	Linear size P (see page 23)
	C:	Linear size C (see page 23)

## 12.1 Shaft Load

The permissible axial and lateral forces are listed in the table on page 21.

The endurance strength of the shaft and the service life on the bearings determine the permissible lateral force  $F_{Rm}$  on the D(rive-End)-side shaft end.

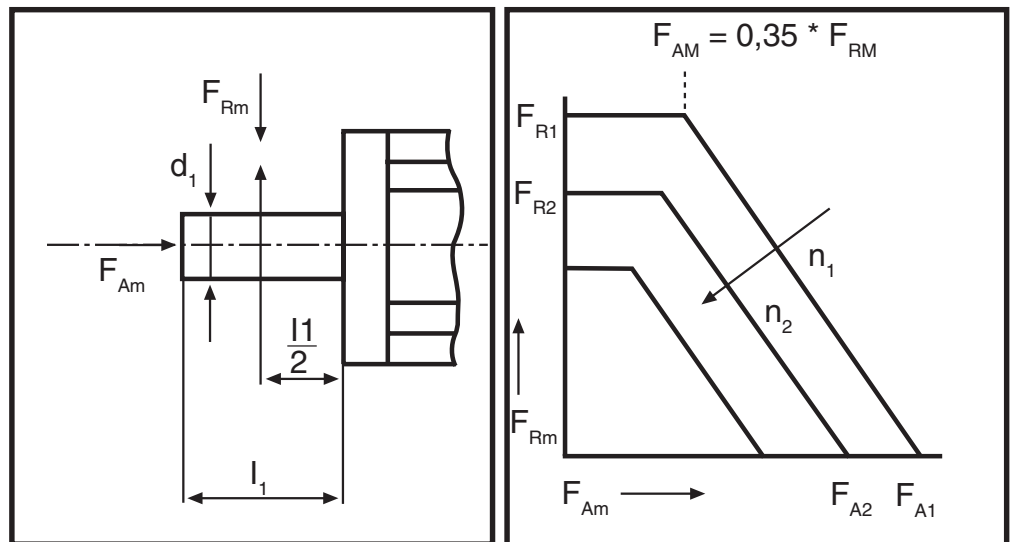

## 12.2 Output Component

The smallest possible effective circular diameter of the output component can be computed as follows:

$$D_w = \frac{k * 2 * M_b}{F_{Rm}}$$

$D_w$ : effective circular diameter of the output components  
 $K$ : pretension factor  
 $F_{Rm}$ : permissible lateral force  
 $M_b$ : acceleration torque of the drive

## 12.3 Pretension Factor

Empirical values for the pretension factor  $k$ :

- ca.  $k = 1,5$  for pinion
- ca.  $k = 1,2$  to  $2,0$  for toothed belt
- ca.  $k = 2,2$  to  $3,0$  for flat belt

For dynamic processes like braking and accelerating, the permissible lateral force  $F_R$  is not to be exceeded in order to avoid a mechanical destruction of the motor.

**12.4 Horizontal Position of Use**

If the lateral force  $F_{R}$  does not take effect at  $x = l_1 / 2$ , changed radial forces occur.

$$F_{Rx} = F_{Rm} * \frac{c + p + 0,5 * l_1}{c + p + x}$$

If the axial force  $F_{AR}$  is not working on the centre of the shaft then the radial parts of this force take effect.

$$F_{AR} = F_{AY} * \frac{y}{p + x}$$

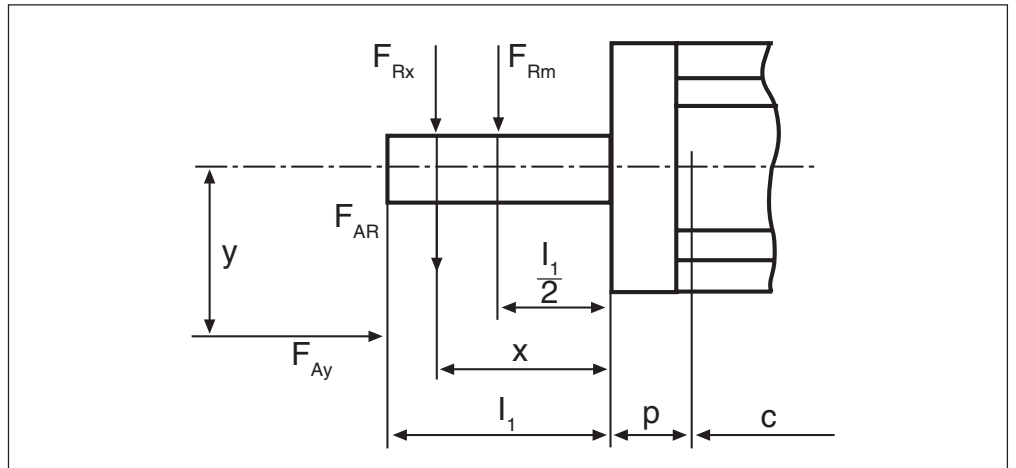

**12.5 Vertical Position of Use**

If the motor is installed vertically, the permissible axial forces  $F_{Am}$  (see table page 21) for the force direction upward apply.

$$F_{Am/ne} w = F_{Am} - F_G$$

$$F_G = m_L * g$$

$m_L$ : mass of rotor

$G$ : gravitational acceleration

For the force direction downward the permissible axial force  $F_{Am}$  is becoming smaller by the mass force  $F_G$  of the rotor.

If the axial force  $F_{Am}$  is working away from the motor then the force  $F_w$  must be taken into account for safety reasons.

$$F_{Am/ne} w = F_{Am} - F_G - F_w$$

$$F_w [N] = 10 * d_1 [mm]$$

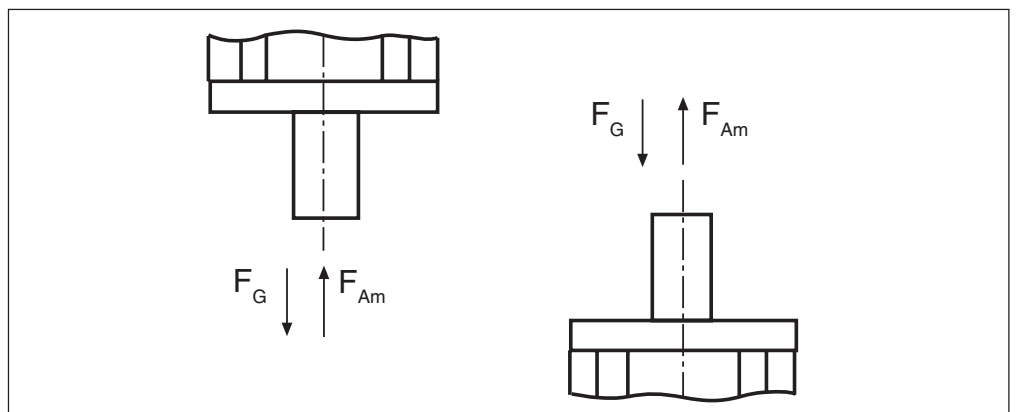

The motors of the series A1...F3 with built-in holding brake are not to be loaded with axial forces, as this causes a change of the working airgap of the holding brake thereby making the brake inoperative.

### 13. Connection

#### 13.1 Connector Assignments

Connection power connector size 1

**Servo motor Power connector (top view)**

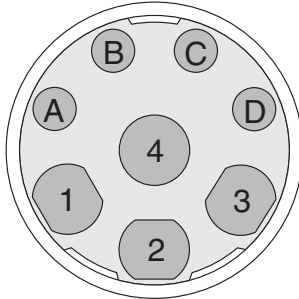

Connector PIN	Designation	Cable Core
1	U	1
4	V	2
3	W	3
2	PE	green-yellow
A	Brake +	5
B	Brake -	6
C	PTC-Contact (T1)	7
D	PTC-Contact (T2)	8

Connection power connector size 1,5

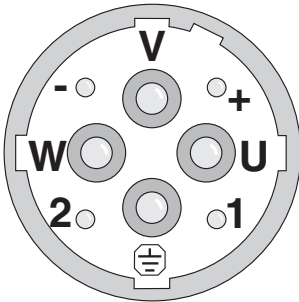

Connector PIN	Designation	Cable Core
U	U	1
V	V	2
W	W	3
PE	PE	green-yellow
+	Brake +	5
-	Brake -	6
1	PTC-Contact (T1)	7
2	PTC-Contact (T2)	8

PTC-connection (230 V / 400 V - Class)	1...3 PTC-detectors (series connection)
max. cold resistance of PTC-detector chain [Ω]	400
Error tripping range [Ω]	≥ 1650
Error reset range [Ω]	≤ 500

Connection resolver

**Servo motor Resolver connector (top view)**

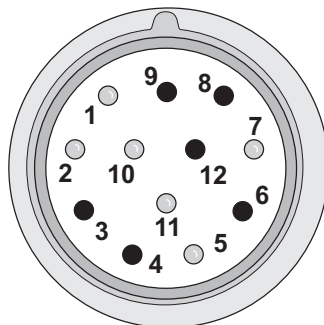

Contacts 3, 4, 6, 8, 9 and 12 are not assigned.

Connection SIN/COS Encoder

**Servo motor SIN/COS-encoder connector (top view)**

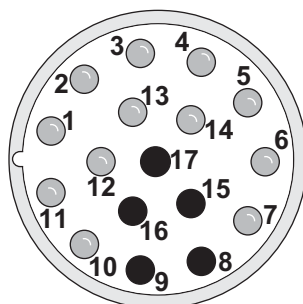

Connector PIN	Designation	Cable Color
1	A (+)	green
2	A (-)	yellow
3	R (+)	gray
4	D (-)	purple
5	C (+)	white
6	C (-)	brown
7	GND	white/green
10	+ 5 V	gray / pink
11	B (+)	blue
12	B (-)	red
13	R (-)	pink
14	D (+)	black

Contacts 8, 9, 15, 16 and 17 are not assigned.

Connection EnDat Encoder

**Servo motor EnDat-encoder connector (top view)**

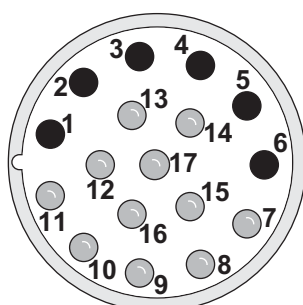

Connector PIN	Designation	Cable Color
7	+5V	white
8	Clock (+)	black
9	Clock (-)	purple
10	COM	brown
12	B (+)	blue
13	B (-)	red
14	Data (+)	gray
15	A (+)	green
16	A (-)	yellow
17	Data (-)	pink

Contacts 1...6 are not assigned.

Connection Hiperface Encoder

**Servo motor Hiperface-encoder connector (top view)**

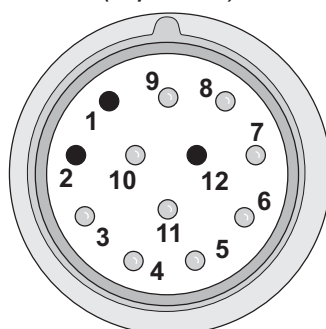

Connector PIN	Designation	Cable Color
4	REF_SIN (-)	red
5	REF_COS (-)	yellow
6	Data (+)	gray
7	Data (-)	pink
8	SIN (+)	blue
9	COS (+)	green
10	+7,5V	brown
11	COM	white

Contacts 1, 2 and 12 are not assigned.

Motor cable and encoder cable

The UL tested motor and encoder cables can be acquired ready-made in different lengths by KEB. The cables are dragable and appropriated for a continuous bending radius of 120 mm.

## 14. Options

### 14.1 Holding Brake

Motor typ		Ax.SM.001-xx00	Bx.SM.001-xx00	Cx.SM.001-xx00
Holding torque	[Nm]	2,0	4,5	9
Moment of inertia	[kgcm <sup>2</sup> ]	0,067	0,183	0,6
max. Speed	[min <sup>-1</sup> ]	10.000	10.000	10.000
Mass	[kg]	0,18	0,30	0,50
Rated voltage	[V]	24 (+6%, -10%)		
Rated current	[A]	0,46	0,50	0,75
Release time t2	[ms]	25	35	40
Engaging delay t11	[ms]	2	2	2
Engaging time t1	[ms]	8	7	7
Power	[W]	11	12	18
Typ		03.P1.330-0567	05.P1.320-0487	06.P1.320-0087

Motortyp		Dx.SM.001-xx00	Ex.SM.001-xx00	Fx.SM.001-xx00
Holding torque	[Nm]	11	36	72
Moment of inertia	[kgcm <sup>2</sup> ]	2,3	5,9	17,6
max. Speed	[min <sup>-1</sup> ]	6.000	10.000	4.000
Mass	[kg]	0,78	1,95	3,8
Rated voltage	[V]	24 (+6%, -10%)		
Rated current	[A]	0,83	1,1	1,67
Release time t2	[ms]	25	90	140
Engaging delay t11	[ms]	3	3	5
Engaging time t1	[ms]	25	22	25
Power	[W]	20	26	40
Typ		08.P1.320-0357	08.P1.320-0057	09.P1.320-0017

The indicated switching times are reached with adjusted nominal air gap (Xmin). There are average values, whose leakage is dependent on the power supply and the coil temperature. The marking of the switching times corresponds to DIN VDE 580.





**Karl E. Brinkmann GmbH**

Försterweg 36-38 • D-32683 Barntrup  
fon: +49 5263 401-0 • fax: +49 5263 401-116  
net: www.keb.de • mail: info@keb.de

**KEB Antriebstechnik GmbH & Co. KG**

Wildbacher Str. 5 • D-08289 Schneeberg  
fon: +49 3772 67-0 • fax: +49 3772 67-281  
mail: info@keb-combidrive.de

**KEB Antriebstechnik Austria GmbH**

Ritzstraße 8 • A-4614 Marchtrenk  
fon: +43 7243 53586-0 • fax: +43 7243 53586-21  
Kostelni 32/1226 • CZ-370 04 České Budejovice  
fon: +420 38 7319223 • fax: +420 38 7330697  
net: www.keb.at • mail: info@keb.at

**KEB Antriebstechnik**

Herenveld 2 • B-9500 Geraadsbergen  
fon: +32 5443 7860 • fax: +32 5443 7898  
mail: vb.belgien@keb.de

**KEB Power Transmission Technology  
(Shanghai) Co. Ltd.**

Industry Development District  
No. 28 Dongbao Road Song Jiang  
CHN-201613 Shanghai, PR. China  
fon: +86 21 51 099 995 • fax: +86 21 67 742 701  
net: www.keb.cn • mail: info@keb.cn

**KEB Antriebstechnik Austria GmbH**

Organizacni slozka  
Kostelni 32/1226  
CZ-370 04 Ceske Budejovice  
fon: +420 38 7699111 • fax: +420 38 7699119  
mail: info.keb@seznam.cz

**KEB España**

C/ Mitjer, Nave 8 - Pol. Ind. LA MASIA  
E-08798 Sant Cugat Sesgarrigues (Barcelona)  
fon: +34 93 897 0268 • fax: +34 93 899 2035  
mail: vb.espana@keb.de

**Société Française KEB**

Z.I. de la Croix St. Nicolas • 14, rue Gustave Eiffel  
F-94510 LA QUEUE EN BRIE  
fon: +33 1 49620101 • fax: +33 1 45767495  
net: www.keb.fr • mail: info@keb.fr

**KEB (UK) Ltd.**

6 Chieftain Buisness Park, Morris Close  
Park Farm, Wellingborough GB-Northants, NN8 6 XF  
fon: +44 1933 402220 • fax: +44 1933 400724  
net: www.keb-uk.co.uk • mail: info@keb-uk.co.uk

**KEB Italia S.r.l.**

Via Newton, 2 • I-20019 Settimo Milanese (Milano)  
fon: +39 02 33500782 • fax: +39 02 33500790  
net: www.keb.it • mail: kebitalia@keb.it

**KEB - YAMAKYU Ltd.**

15-16, 2-Chome, Takanawa Minato-ku  
J-Tokyo 108-0074  
fon: +81 33 445-8515 • fax: +81 33 445-8215  
mail: info@keb.jp

**KEB Taiwan Ltd.**

No.8, Lane 89, Sec.3; Taichung Kang Rd.  
R.O.C.-Taichung City / Taiwan  
fon: +886 4 23506488 • fax: +886 4 23501403  
mail: info@keb.com.tw

**KEB Korea Seoul**

Room 1709, 415 Missy 2000  
725 Su Seo Dong, Gang Nam Gu  
ROK-135-757 Seoul/South Korea  
fon: +82 2 6253 6771 • fax: +82 2 6253 6770  
mail: vb.korea@keb.de

**KEB Sverige**

Box 265 (Bergavägen 19)  
S-43093 Hälsö  
fon: +46 31 961520 • fax: +46 31 961124  
mail: vb.schweden@keb.de

**KEB America, Inc.**

5100 Valley Industrial Blvd. South  
USA-Shakopee, MN 55379  
fon: +1 952 224-1400 • fax: +1 952 224-1499  
net: www.kebamerica.com • mail: info@kebamerica.com